

SCH-T78

特性 Features

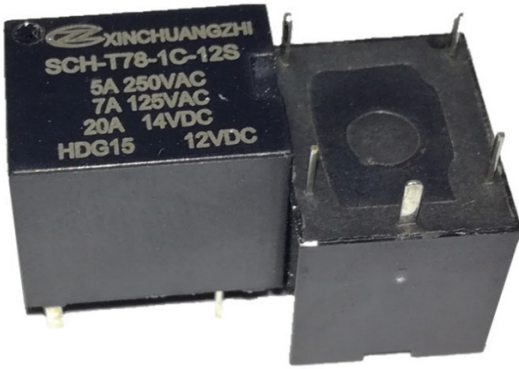

- | | |
|---------------------|---|
| 1. 20A 触点切换能力 | 20A switching capability |
| 2. 具有 250VAC 负载能力 | possess 250VAC |
| 3. 触点与线圈间介质耐压 750VA | Dielectric strength 750VA.(between coil and contacts) |
| 4. 一组常开触点和一组转换形式 | 1Form A&1 form C configurations available |
| 5. 塑封和防尘罩型可选 | Wash tight and flux proofed types available |
| 6. F 级绝缘等级 | Thermal class F |
| 7. 环保产品 (符合 RoHS) | Environmental friendly product (RoHS) |
| 9. 外形尺寸 | Outline Dimensions: (15.5x 12.1x 13.8) mm |

触点数据 Contact data

触点形式 Contact Arrangement	1A(1H)	1B(1D)	1C(1Z)
触点材料 Contact Material	Ag Alloys		
触点负载(阻性) Contact Rating(Resistive)	20A 14VDC 7A 125VAC	5A 250VAC	NO:20A 14VDC NC:10A 14VDC
最大切换功率 Max.Switching Power	1250VA		
最大切换电压 Max.Switching Voltage	250VAC		
最大切换电流 Max.Switching Current	20A		
触点阻性 Contact Resistance	$\leq 100m\Omega$ (1A24VDC)		
寿命 Operation Life	电气 Electrical	1×10^5 ops	
	机械 Mechanical	1×10^7 ops	

线圈参数 Coil Parameter

额定线圈功率 Rated coil power 标准型: 约 600mW

线圈电压 Coil voltage VDC	吸合电压 Pick up Voltage VDC	释放电压 Release voltage VDC	最大电压 Max voltage VDC	额定电流 Nominal Current mA	线圈电阻 Coil Resistance Ω (1 \pm 10%)	线圈功耗 Coil power consumption W
5	75% Maximum	10% Minimum	130%	119	42	0.60
6				100	60	0.60
9				66.7	135	0.60
12				50	240	0.60
24				25	960	0.60
36				16.7	2156	0.60
48				12.5	3840	0.60

注意:1,使用的线圈电压低于线圈额定电压时将会损害继电器的工作.

2,吸合,释放电压仅供检测用,不是设计的使用指标.

Caution:1,The use of any coil voltage less than the rated coil voltage will compromise the operation of the relay.

2,Pick up and release voltage are for test purposes only and are not be used as design criteria.

技术特性 Operation condition	
绝缘电阻 Insulation Resistance	1000M Ω
介质耐压 Dielectric Strength	
断开触点间 Between Contacts	750VAC
触点与线圈间 Between Contacts and Coil	750VA
动作时间（额定电压下） Action time (rated voltage)	≤ 15ms
释放时间（额定电压下） Release time (rated voltage)	≤ 5ms
耐冲击 Shock Resistance	98m/s ² 980m/s ²
抗振性 Vibration Resistance	10Hz~55Hz 1.5mm 双振幅 Double amplitude 1.5mm
引出端强度 Terminals Strength	6N
可焊性 Solderability	280±10℃ 2±1s℃
环境温度 Ambient Temperature	-40~85℃
相当湿度 Relative Humidity	5%~85% RH
质(重)量 Mass	约 6g

订货信息 Ordering information

SCH - T78 - 1A - 12 - S				
1	2	3	4	5

- 1, 总称 generic terms
- 2 型号 Part number:
- 3, 触点形式 Contact Arrangement: 1A 常开 (NO), 1B 常开 (NC), 1C 常开 (NO NC)
- 4, 线圈额定电压 Coil rated voltage(V): 5 6 9 12 24 36 48VDC
线圈功率 coil power: 空白=0.6w
- 5, 塑封类型 Seal type: S 密封型 无 防尘型

备注:

(1)在洁净环境（不含 H₂S SO₂ NO₂, 粉尘等污染物）下使用时，推荐使用防焊剂产品。
在污染环境（含一定量 H₂S SO₂ NO₂, 粉尘等污染物）下使用时，建议使用塑封产品，并在实际使用中确认。

(2)当继电器装入 PCB 板后，如需进行整体清洗，请与我司联系确认，以便提供合适的产品。当不需要整体清洗时，建议优先选用防焊剂产品；

(3)常规产品为黑色外壳，若需其他颜色外壳颜色可特殊定做。

(4)客户特殊要求经我司评审后，按特性号的形式标示。

外形尺寸 Dimensions(mm/Inch)

1A(1H)

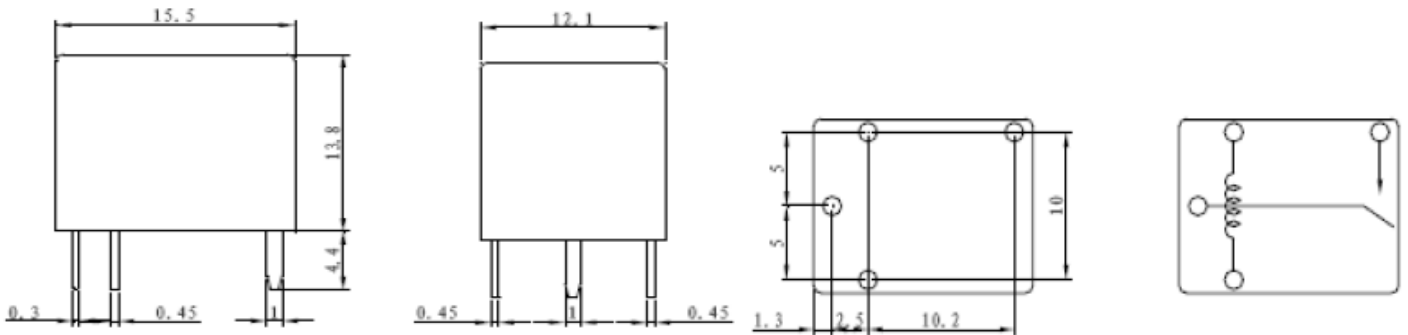

1B (1D)

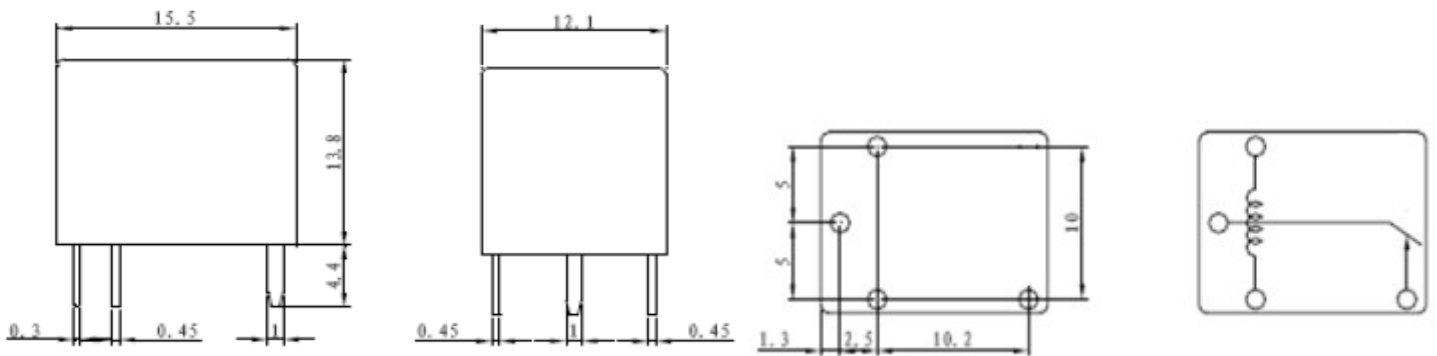

1C (1Z)

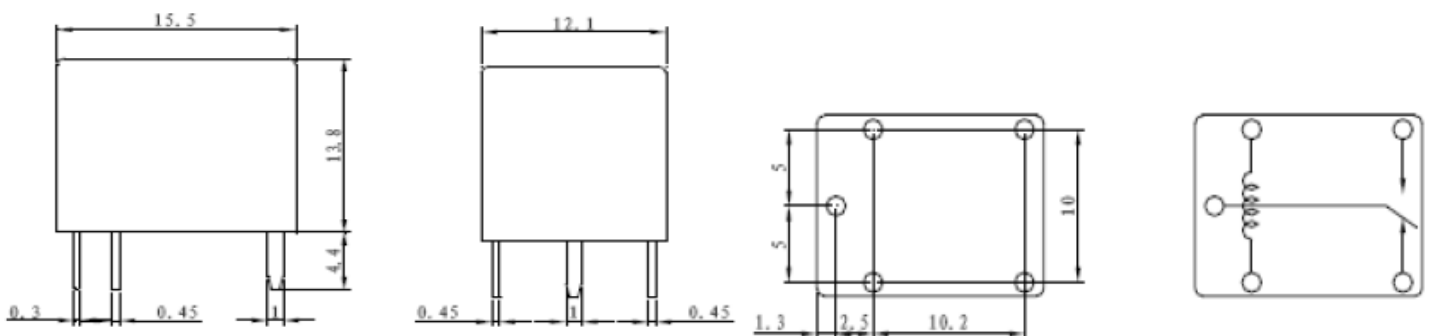

声明:

本产品说明书仅供客户使用时参考, 若有更改, 恕不另行通知

This datasheet is for the customers'. All the specification are subject to change without notice.

对我司而言, 不可能评定继电器在每个具体应用领域的所有性能参数要求, 因而客户应根据具体的使用条件选择与之相匹配的产品, 若有疑问, 请与我司联系以便获取更多的技术支持, 但产品选型责任仅由客户负责。

We could not evaluate all the performance and all the parameters for every possible application.

Thus the user should be in a right position to choose the suitable product for their own application. if there is any query, please contact xinchuangzhi for the technical service. However, it is the user's responsibility to determine which product should be used only.

© 宁波信创智电器有限公司版权所有, 本公司保留所有权利

© NingBo XinChuangZhi Electric appliance Co.Ltd, All rights of XinChuangZhi are reserved